

Specification sheet LX 475

**Parapet roof drainage systems
Series 89 RAINSTAR®
with roof penetration of 55 mm**

Emergency flow

Gravity flow

Silent Power

Abfluss:	8,2 l/sec
Water height:	75 mm
Roof penetration:	55 mm
Diameter:	DN 70
LX-Number:	LX 475
Weir height:	35 mm
Drain:	ventilated
Downpipe:	not ventilated
Downpipes height:	4,2 m
Drainage:	on floor
Flange form:	Klemmflansch

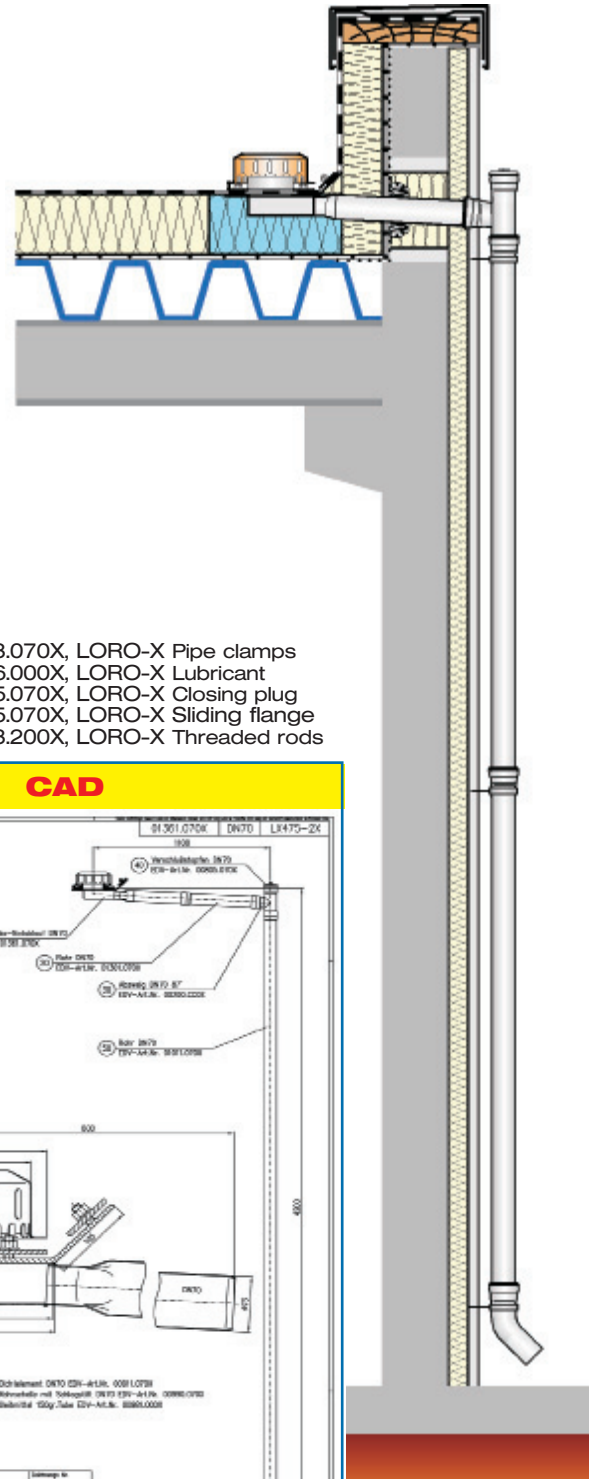

LX 475 Piece list

- 1 x Art.-No. 01301.070X, LORO-X Pipe with one socket
- 1 x Art.-No. 00200.CC0X, LORO-X Branch
- 1 x Art.-No. 01011.070X, LORO-X Pipe with one socket
- 1 x Art.-No. 00320.070X, LORO-X Bend
- 4 x Art.-No. 00911.070X, LORO-X Sealing elements

- 3 x Art.-No. 00973.070X, LORO-X Pipe clamps
- 1 x Art.-No. 00986.000X, LORO-X Lubricant
- 1 x Art.-No. 00805.070X, LORO-X Closing plug
- 1 x Art.-No. 13235.070X, LORO-X Sliding flange
- 3 x Art.-No. 09603.200X, LORO-X Threaded rods

hQ - Head-Discharge curve

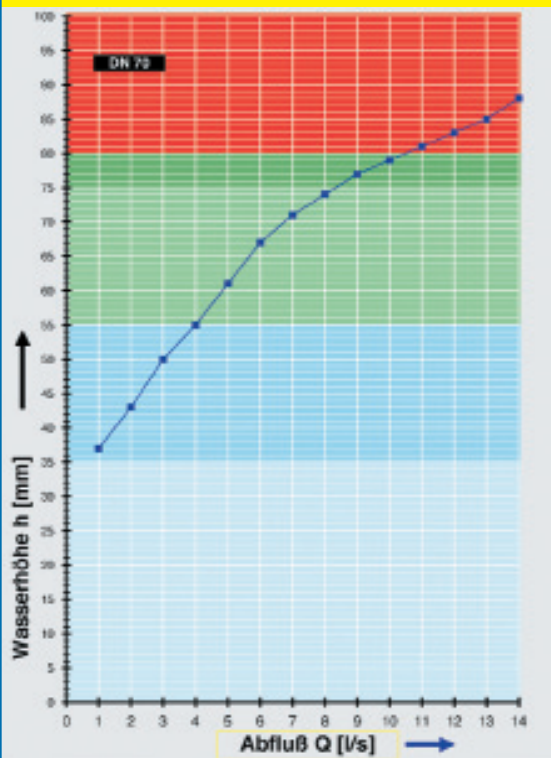

Systempower

CAD

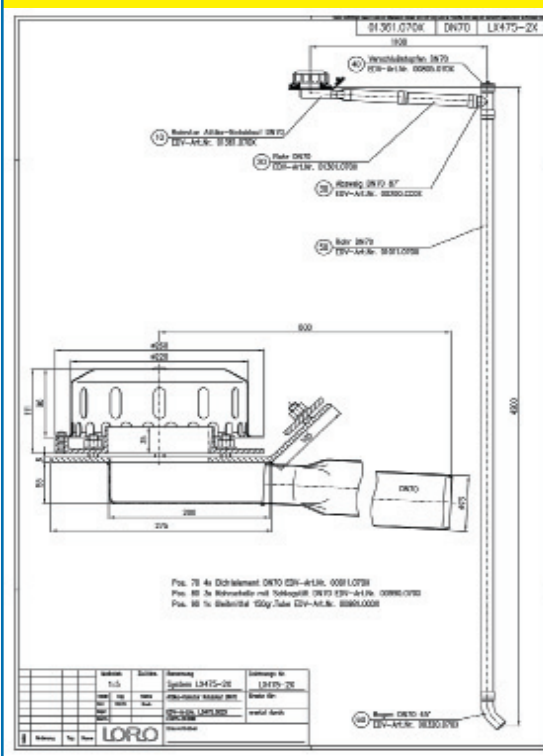

Systemshape

Water height	mm	5	10	15	20	25	30	35	40	45	50	55	60	65	70	75
Discharge	l/sec								1,5	2,3	3,0	4,0	4,8	5,6	6,8	8,2
									Silent			Silent Power				

Choose drain for piece list on page one!

DN 70

LX475-1X

Drain Art.-No. 01363.070X
Weight: 8,3 kg

Series 89
with roof penetration of 55 mm
clamping flange 90°
for plastic roofing sheets

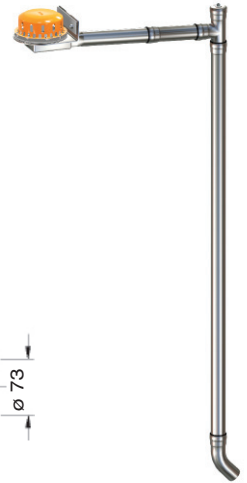
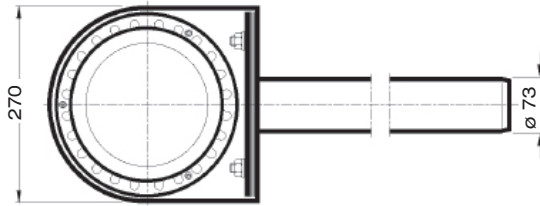
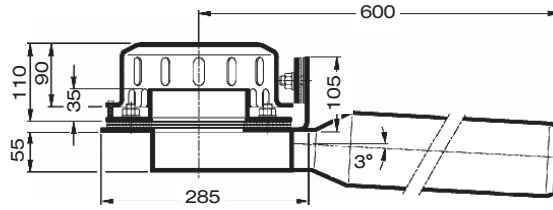

LX475-2X

Drain Art.-No. 01361.070X
Weight: 8,1 kg

Series 89
with roof penetration of 55 mm
clamping flange 45°
for bituminous roofing sheets

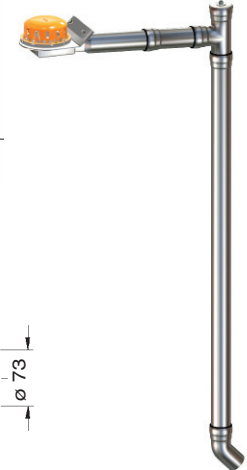
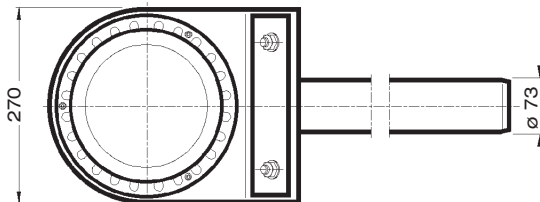
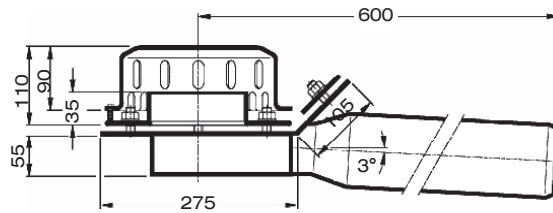

Heat tracing: Lorowerk recommends to check all drains and pipes with regard to their frost-sensibility. Where necessary, these parts should be upgraded with heat tracing.